

ATK FLEXIBLE FLANGED ADAPTOR

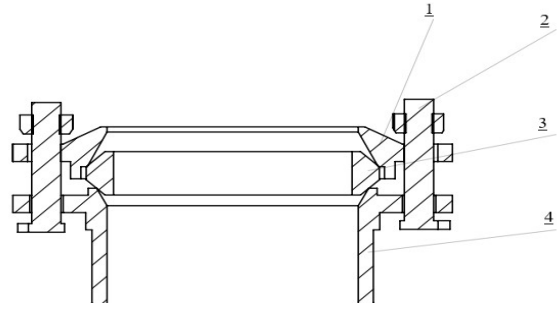

- ❖ **Function:** To connect PE, PVC, Ductile iron, steel pipes to flange.
- ❖ **Structure:** Ductile iron FCD 450, fusion bonded epoxy coating. Working pressure 16 Bar. Cone rubber ring. Accommodate BS flange drillings. Connection type: Flange joint

No.	Part	Materials
1	Top cover	Ductile iron
2	'T' Bolts, nuts and washers	Ductile Iron
3	Ring	EPDM
4	Body	Ductile iron

❖ **Standard :** ISO 2531-2009

❖ **Specifications (mm):**

No.	Flange Adaptor (DN)	Pipe range (OD mm)	L (mm)	Weight (Kg)	Bolts MxL1	Number of bolts
1	DN 50	60-63	54	3	M12x60	4
2	DN 65	70-75	55	3,2	M12x60	4
3	DN 80	85-90	60	4	M14x70	4
4	DN 100	110-120	110	6,2	M14x70	4
5	DN 125	122-132	62	7,3	M14x70	4
6	DN 140	140-160	80	7,5	M14X70	4
7	DN 150	160-170	130	8,9	M14X70	4
8	DN 180	180-185	135	14	M16X100	4
9	DN 200	200-220	140	14,5	M16X100	4
10	DN 225	225-230	140	16,4	M16x100	4
11	DN 250	250-274	150	21,4	M16x100	6
12	DN 300	280-284	150	24	M16x100	6
13	DN 350	315-325	150	32	M18x130	6
14	DN 400	350-360	155	43	M18x130	8
15	DN 450	400-426	160	52	M18x130	10
16	DN 500	500-525	200	64	M18x130	10
17	DN 600	600-630	220	78	M20x130	10